

1. Finish Goods PKG photo



2. Packing method

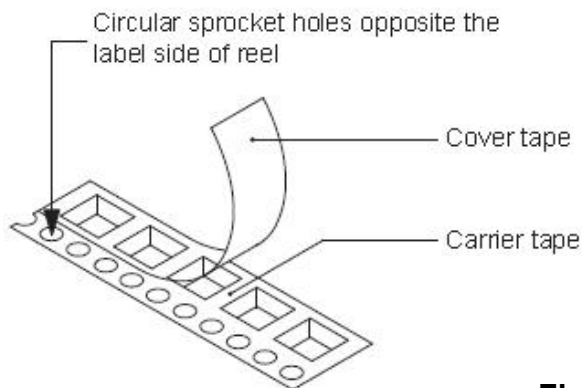
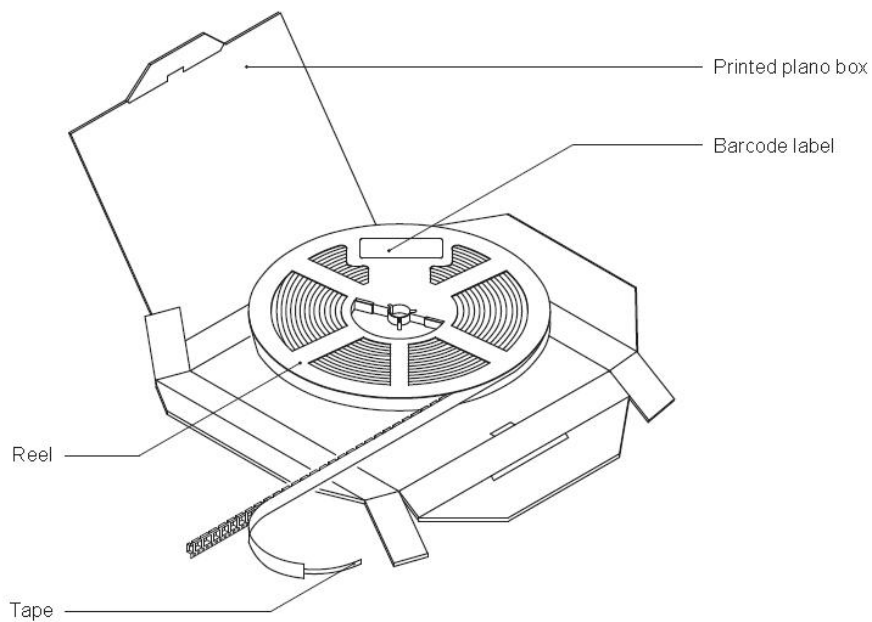

Fig.1- Reel pack for SMD

B040, Rev. -

Table 1. Packing information

Package version	Reel dimensions $\phi \times H$ (mm)	SPQ/PQ (pcs)	Reels per box	Inner box dimensions L×W×H (mm)
ABF	$\Phi 330 \times 12$	5000	2	340×340×28

3. Product orientation

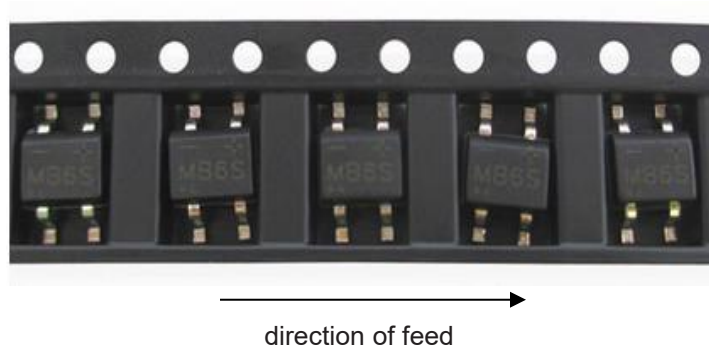

Fig 2. Product orientation in carrier tape

4. Carrier tape dimensions

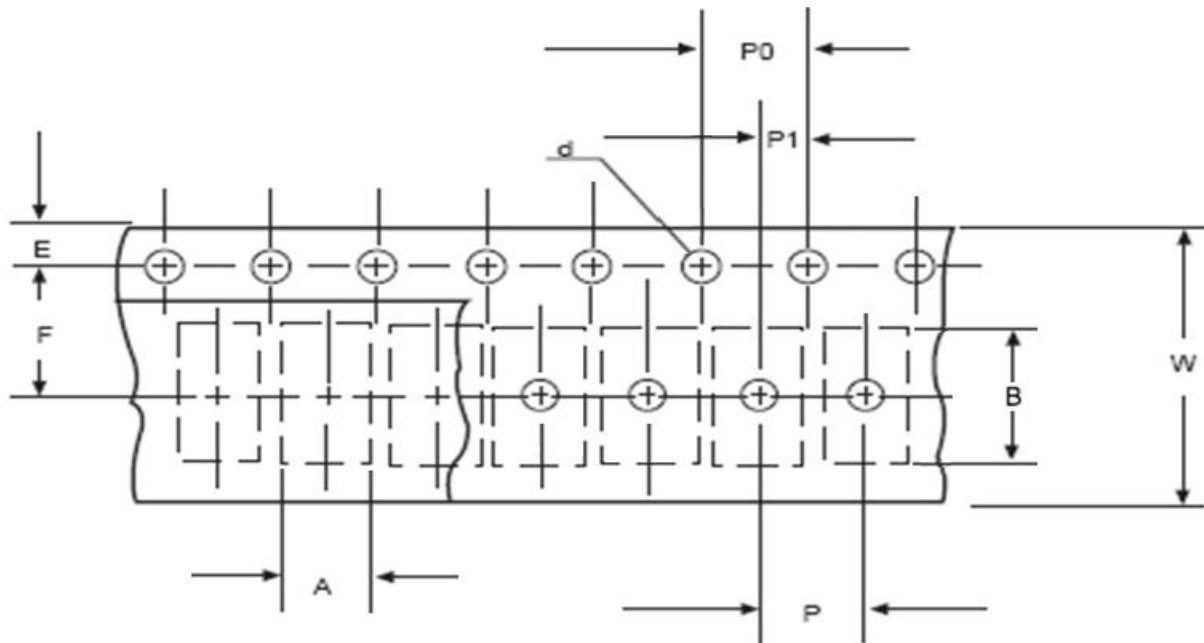

Fig 3. Carrier tape dimensions

5. Reel dimensions

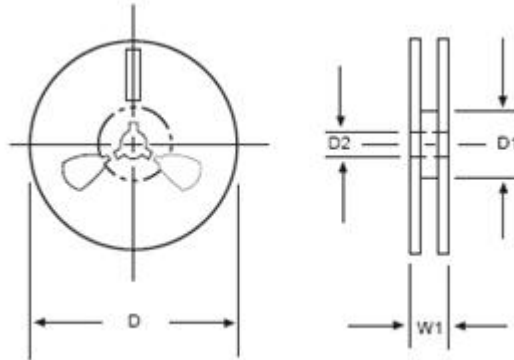

Fig 4. Reel dimensions

Table 2. Carrier tape dimensions

ITEM	SYMBOL	DO-218AB mm
Carrier width	A	5.2±0.2
Carrier length	B	6.6±0.2
Sprocket hole	d	1.5±0.1
Reel outside diameter	D	330±2.0
Reel inner diameter	D1	8.0±0.2
Feed hole diameter	D2	13±0.5
Sprocket hole position	E	1.5±0.1
Punch hole position	F	5.65±0.1
Punch hole pitch	P	4.0±0.1
Sprocket hole pitch	P0	4.0±0.1
Embossment center	P1	2.0±0.1
Tape width	W	12±0.5
Reel width	W1	14±1